Echo[®] MS Core Module

User Guide



This document is provided to customers who have purchased SCIEX equipment to use in the operation of such SCIEX equipment. This document is copyright protected and any reproduction of this document or any part of this document is strictly prohibited, except as SCIEX may authorize in writing.

Software that may be described in this document is furnished under a license agreement. It is against the law to copy, modify, or distribute the software on any medium, except as specifically allowed in the license agreement. Furthermore, the license agreement may prohibit the software from being disassembled, reverse engineered, or decompiled for any purpose. Warranties are as stated therein.

Portions of this document may make reference to other manufacturers and/or their products, which may contain parts whose names are registered as trademarks and/or function as trademarks of their respective owners. Any such use is intended only to designate those manufacturers' products as supplied by SCIEX for incorporation into its equipment and does not imply any right and/or license to use or permit others to use such manufacturers' and/or their product names as trademarks.

SCIEX warranties are limited to those express warranties provided at the time of sale or license of its products and are the sole and exclusive representations, warranties, and obligations of SCIEX. SCIEX makes no other warranty of any kind whatsoever, expressed or implied, including without limitation, warranties of merchantability or fitness for a particular purpose, whether arising from a statute or otherwise in law or from a course of dealing or usage of trade, all of which are expressly disclaimed, and assumes no responsibility or contingent liability, including indirect or consequential damages, for any use by the purchaser or for any adverse circumstances arising therefrom.
(GEN-IDV-09-10816-D)

For Research Use Only. Not for use in Diagnostic Procedures.

Trademarks and/or registered trademarks mentioned herein, including associated logos, are the property of AB Sciex Pte. Ltd., or their respective owners, in the United States and/or certain other countries (see sciex.com/trademarks).

AB SCIEX™ is being used under license.

Echo® and Echo® MS are trademarks or registered trademarks of Labcyte, Inc. in the United States and other countries, and are being used under license.

© 2022 DH Tech. Dev. Pte. Ltd.



AB Sciex Pte. Ltd.
Blk33, #04-06 Marsiling Industrial Estate Road 3
Woodlands Central Industrial Estate, Singapore 739256

Contents

1 Operational Precautions and Limitations	5
General Safety Information.....	5
Documentation Symbols and Conventions.....	5
Regulatory Compliance.....	6
Australia and New Zealand.....	6
Canada.....	6
Europe.....	6
United States.....	7
International.....	7
Electrical Precautions.....	7
Mains Supply.....	8
Protective Earth Conductor.....	8
Chemical Precautions.....	9
Ventilation Precautions.....	10
Physical Precautions.....	11
Environmental Precautions.....	11
Electromagnetic Environment.....	12
Decommissioning and Disposal.....	13
Qualified Personnel.....	13
Laboratory Conditions.....	14
Safe Environmental Conditions.....	14
Performance Specifications.....	14
Equipment Use and Modification.....	14
2 Principles of Operation	16
System Overview.....	16
Hardware Overview.....	17
Panel Symbols.....	23
Theory of Operation.....	23
3 Operating Instructions—Device Configuration	24
Add an Echo [®] MS Core Module Device.....	24
Deactivate Devices.....	25
4 System Preparation	26
Fluid Line Connections.....	26
Prerequisites.....	28
Start Up the Echo [®] MS Module.....	28
Purge the Flow Lines.....	30
5 Method Developer Workflow	32

Contents

6 Operating Instructions	35
Prepare the Plates.....	35
Load the Plate Manually.....	36
Load the Plate Using Software.....	36
Load the Plate Using Hardware.....	36
Submit the Batch and then Start the Acquisition.....	37
Emergency Off Function.....	37
Use the Emergency Off Button.....	40
Reset the Emergency Off Button.....	41
7 Routine Maintenance	43
Flush the Electrode Assembly After Acquisition.....	43
Turn off the Echo [®] MS System.....	43
Resume the Echo [®] MS System after a Power Shutdown.....	43
Waste Disposal.....	44
Clean the Surfaces.....	44
Add the Mobile Phase Solvent.....	44
Replace the Coupling Fluid.....	46
8 Troubleshooting	48
Inspect the Fluidics Module.....	48
A Glossary of Symbols	49
B Glossary of Warnings	55
Contact Us	56
Customer Training.....	56
Online Learning Center.....	56
SCIEX Support.....	56
CyberSecurity.....	56
Documentation.....	56

Operational Precautions and Limitations

1

Note: Before operating the system, carefully read all of the sections of this guide.

This section contains general safety-related information and provides regulatory compliance information. It also describes potential hazards and associated warnings for the system and the precautions that should be taken to minimize the hazards.

In addition to this section, for information about the symbols used in the laboratory environment, on the system, and in this documentation, refer to the section: [Glossary of Symbols](#). For site requirements, refer to the document: *Site Planning Guide*.

General Safety Information

To prevent personal injury or system damage, read, understand, and obey all of the safety precautions and warnings in this document, the manufacturer chemical safety data sheets (SDSs), and product label information. Labels are shown with internationally recognized symbols. Failure to heed these warnings could result in serious injury.

This safety information is intended to supplement federal, state, provincial, and local environmental health and safety (EHS) regulations. The information provided covers system-related safety information applicable to the operation of the system. It does not cover every safety procedure that should be practiced. Ultimately, the user and the organization are responsible for compliance with federal, state, provincial, and local EHS regulations and for maintaining a safe laboratory environment.

Refer to the appropriate laboratory reference material and standard operating procedures.

Documentation Symbols and Conventions

The following symbols and conventions are used throughout the guide.



DANGER! Danger signifies an action that leads to severe injury or death.



WARNING! Warning signifies an action that could cause personal injury if precautions are not followed.

Operational Precautions and Limitations

CAUTION: Caution signifies an operation that could cause damage to the system or corruption or loss of data if precautions are not followed.

Note: Note emphasizes significant information in a procedure or description.

Tip! Tip provides useful information that helps apply the techniques and procedures in the text for a specific need and provides shortcuts, but is not essential to the completion of a procedure.

Regulatory Compliance

This system complies with the regulations and standards listed in this section. For dated references, refer to the *Declaration of Conformity* included with the system and the individual system components. Applicable labels have been affixed to the system.

Australia and New Zealand

- **Electromagnetic Compatibility (EMC):** Radio Communications Act 1992 as implemented in these standards:
 - Electromagnetic Interference—AS/NZS CISPR 11/ EN 55011/ CISPR 11 (Class A). Refer to the section: [Electromagnetic Interference](#).

Canada

- **Electromagnetic Interference (EMI):** CAN/CSA CISPR11. This ISM device complies with Canadian ICES-001. Refer to the section: [Electromagnetic Interference](#).
- **Safety:**
 - CAN/CSA C22.2 No. 61010-1

Europe

- **Electromagnetic Compatibility (EMC):** Electromagnetic Compatibility Directive 2014/30/EU as implemented in these standards:
 - EN 61326-1
 - EN 55011 (Class A)Refer to the section: [Electromagnetic Compatibility](#).

- **Safety:** Machinery Directive 2006/42/EC as implemented in these standards:
 - EN 61010-1
- **Waste Electrical and Electronic Equipment (WEEE):** Waste Electrical and Electronic Equipment Directive 2012/96/EEC, as implemented in EN 40519. Refer to the section: [Waste Electrical and Electronic Equipment](#).
- **Packaging and Packaging Waste (PPW):** Packaging and Packaging Waste Directive 94/62/EC
- **RoHS Restriction of Hazardous Substances:** RoHS Directive 2011/65/EU and 2015/863/EU

United States

- **Radio Emissions Interference Regulations:** 47 CFR 15, as implemented in FCC Part 15 (Class A)
- **Safety:** Occupational Safety and Health Regulations, 29 CFR 1910, as implemented in these standards:
 - UL 61010-1

International

- **Electromagnetic Compatibility (EMC):**
 - IEC 61326-1
 - IEC CISPR 11 (Class A)Refer to the section: [Electromagnetic Compatibility](#).
- **Safety:**
 - IEC 61010-1

Electrical Precautions



WARNING! Electrical Shock Hazard. Do not remove the covers. Removing the covers might cause injury or malfunctioning of the system. The covers need not be removed for routine maintenance, inspection, or adjustment. Contact a SCIEX Field Service Employee (FSE) for repairs that require the covers to be removed.

- Follow required electrical safe work practices.
- Use cable management practices to control electrical cables. This will decrease the chance of a tripping hazard.

Operational Precautions and Limitations

For information about system electrical specifications, refer to the document: *Site Planning Guide*.

Mains Supply

Connect the system to a compatible mains supply as instructed in this guide.



WARNING! Electrical Shock Hazard. Use only qualified personnel for the installation of all of the electrical supplies and fixtures, and make sure that all of the installations adhere to local regulations and safety standards.



WARNING! Electrical Shock Hazard. Make sure that the system can be disconnected from the mains supply outlet in an emergency. Do not block the mains supply outlet.



WARNING! Electrical Shock Hazard. Use only the mains supply cables supplied with the system. Do not use mains supply cables that are not properly rated for the operation of this system.

CAUTION: Potential System Damage. Do not unpack or connect any system components. The FSE will unpack, connect, and configure the system for the proper operating voltage.

Protective Earth Conductor

The mains supply must include a correctly installed protective earth conductor. The protective earth conductor must be installed or examined by a qualified electrician before the system is connected.



WARNING! Electrical Shock Hazard. Do not intentionally interrupt the protective earth conductor. Any interruption of the protective earth conductor creates an electrical shock hazard.



WARNING! Electrical Shock Hazard. Make sure that a protective earth conductor (grounding cable) is connected between the sample loop and an appropriate grounding point at the ion source. This supplementary grounding reinforces the safety configuration specified by SCIEX.

Chemical Precautions



WARNING! Ionizing Radiation Hazard, Biohazard, or Toxic Chemical Hazard. Determine whether decontamination is required before cleaning or maintenance. If radioactive materials, biological agents, or toxic chemicals have been used with the system, then the customer must decontaminate the system before cleaning or maintenance.



WARNING! Puncture Hazard, Ionizing Radiation Hazard, Biohazard, or Toxic Chemical Hazard. Discontinue use of the ion source if the ion source window is cracked or broken, and then contact a SCIEX Field Service Employee (FSE). Any toxic or injurious materials introduced in the equipment will be present in the source exhaust output. Exhaust from equipment should be vented from the room. Dispose of sharps following established laboratory safety procedures.



WARNING! Environmental Hazard. Do not dispose of system components in municipal waste. Follow local regulations when disposing of components.

CAUTION: Potential System Damage. Do not submerge the end of the drain tubing in the waste liquid in the waste container.

- Determine which chemicals have been used in the system prior to service and regular maintenance. For the health and safety precautions that must be followed for a chemical, refer to the document: *Safety Data Sheet*. For storage information, refer to the document: *Certificate of Analysis*. To find a SCIEX *Safety Data Sheet* or *Certificate of Analysis*, go to sciex.com/tech-regulatory.
 - Always wear assigned personal protective equipment, including powder-free gloves, safety glasses, and a laboratory coat.
-

Note: Nitrile or neoprene gloves are recommended.

- Work in a well-ventilated area or fume hood.
 - Avoid ignition sources when working with flammable materials, such as isopropanol, methanol, and other flammable solvents.
 - Take care in the use and disposal of any chemicals. There is a potential risk of personal injury if proper procedures for handling and disposal of chemicals are not followed.
-

Operational Precautions and Limitations

- Avoid skin contact with chemicals during cleaning, and wash hands after use.
- Collect all spent liquids and dispose of them as hazardous waste.
- Comply with all of the local regulations for the storage, handling, and disposal of biohazardous, toxic, and radioactive materials.

Ventilation Precautions

The venting of fumes and disposal of waste must comply with all of the federal, state, provincial, and local health and safety regulations. It is the responsibility of the customer to make sure that the air quality is maintained in compliance with local health and safety regulations.



WARNING! Ionizing Radiation Hazard, Biohazard, or Toxic Chemical Hazard. Take care to vent exhaust gases to a dedicated laboratory fume hood or exhaust system and make sure that the ventilation tubing is secured with clamps. Make sure that the laboratory has appropriate air exchange for the work performed.



WARNING! Flammable Chemical Hazard, Biohazard, Ionizing Radiation Hazard, and Toxic Chemical Hazard. Be sure to use the system in a well-ventilated laboratory environment in compliance with local regulations and with appropriate air exchange for the work performed. Solvents used in high performance liquid chromatography are flammable and toxic.



WARNING! Ionizing Radiation Hazard, Biohazard, or Toxic Chemical Hazard. Do not use the ion source without knowledge of and training in the proper use, containment, and evacuation of toxic or injurious materials used with the ion source.



WARNING! Puncture Hazard, Ionizing Radiation Hazard, Biohazard, or Toxic Chemical Hazard. Discontinue use of the ion source if the ion source window is cracked or broken, and then contact a SCIEX Field Service Employee (FSE). Any toxic or injurious materials introduced in the equipment will be present in the source exhaust output. Exhaust from equipment should be vented from the room. Dispose of sharps following established laboratory safety procedures.

Physical Precautions



WARNING! Hot Surface Hazard. Let the OptiFlow Turbo V ion source cool for at least 40 minutes before starting any maintenance procedures. Some surfaces of the ion source and vacuum interface become hot during operation.



WARNING! Lifting Hazard. Use a mechanical lifting device to lift and move the Echo[®] MS module. If the Echo[®] MS module must be moved manually, then at least four people are required to move it safely. Follow established safe lifting procedures. For the weights of system components, refer to the document: *Site Planning Guide*.

Environmental Precautions

Use qualified personnel for the installation of electrical mains, heating, ventilation, and plumbing supplies and fixtures. Make sure that all of the installations comply with local bylaws and biohazard regulations. For information about the required environmental conditions for the system, refer to the document: *Site Planning Guide*.

Allow access space around the equipment when setting up the system.



DANGER! Explosion Hazard. Do not operate the system in an environment containing explosive gases. The system is not designed for operation in an explosive environment.



WARNING! Fire Hazard. Do not operate the system in the presence of an open flame, or in the same room as equipment that could potentially emit sparks.



WARNING! Biohazard. For biohazardous material use, always comply with local regulations for hazard assessment, control, and handling. This system or any part is not intended to act as a biological containment.



WARNING! Environmental Hazard. Follow established procedures for disposal of biohazardous, toxic, radioactive, and electronic waste. The customer is responsible for disposal of hazardous substances, including chemicals, waste oils, and electrical components, in accordance with local laws and regulations.

Operational Precautions and Limitations



WARNING! Fire Hazard. Do not use flammable sprays, such as hair sprays or insecticide sprays, near the system. They could ignite and cause a fire.

CAUTION: Potential System Damage. Avoid exposure to corrosive gas and excessive dust.

CAUTION: Potential System Damage. Take precautions to prevent the system from falling in the event of an earthquake.

Electromagnetic Environment

Electromagnetic Compatibility

Basic Electromagnetic Environment: Environment existing at locations characterized by being supplied directly at low voltage from the public mains network.

The equipment is intended for use in a basic electromagnetic environment.

The expected performance loss under the electromagnetic immunity conditions is less than 20% change in total ion count (TIC).

Make sure that a compatible electromagnetic environment for the equipment can be maintained so that the device will operate as intended. If the power supply line is subject to high electrical noise, then install a surge protector.

Electromagnetic Interference

Group 1 Equipment: This equipment is classified as industrial, scientific, and medical (ISM) equipment that might use RF energy for internal operation.

Class A Equipment: Equipment which is suitable for use in all establishments other than domestic and those directly connected to a low voltage power supply network which supplies buildings used for domestic purposes. [Derived from CISPR 11:2009, 5.3] Class A equipment shall meet Class A limits.

CAUTION: Potential Radio Interference. This equipment is not intended for use in residential environments and may not provide adequate protection to radio reception in such environments.

This equipment has been tested and found to comply with the limits for a Class A digital device, pursuant to Part 15 of the FCC (Federal Communications Commission) Compliance Rules.

These limits are designed to provide reasonable protection against harmful interference when the equipment is operated in a commercial environment. This equipment generates, uses, and can

radiate radio frequency energy and, if not installed and used in accordance with the operator's manual, can cause harmful interference to radio communications.

Operation of this equipment in a residential area is likely to cause harmful interference in which case you will be required to correct the interference, at your own expense. Changes or modifications not expressly approved by the manufacturer could void your authority to operate the equipment.

Decommissioning and Disposal



WARNING! Environmental Hazard. Follow established procedures for disposal of biohazardous, toxic, radioactive, and electronic waste. The customer is responsible for disposal of hazardous substances, including chemicals, waste oils, and electrical components, in accordance with local laws and regulations.

Before decommissioning, decontaminate the entire system following local regulations.

When removing the system from service, separate and recycle different materials according to national and local environmental regulations.

Note: SCIEX will not accept any system returns without a completed Decontamination Form. Contact an FSE to obtain a copy of the form.

Do not dispose of system components or subassemblies, including computer parts, as unsorted municipal waste.

Waste Electrical and Electronic Equipment

Follow local municipal waste ordinances for proper disposal provisions to reduce the environmental impact of waste, electrical, and electronic equipment (WEEE). To safely dispose of this equipment, contact a local Customer Service office for complimentary equipment pick-up and recycling.

Qualified Personnel

Only qualified SCIEX personnel shall install, inspect, and service the equipment. After installing the system, the Field Service Employee (FSE) uses the *Customer Familiarization Checklist* to orient the customer on system operation, cleaning, and basic maintenance. SCIEX might not cover the damage to a system under warranty if it is serviced by personnel not authorized by SCIEX.

Only personnel qualified by the manufacturer shall maintain the equipment. A laboratory designate can be familiarized with the Qualified Maintenance Person (QMP) procedures during the installation. A QMP is a person who is suitably aware of the electrical and chemical risks associated with servicing laboratory equipment.

Laboratory Conditions

Safe Environmental Conditions

The system is designed to operate safely under these conditions:

- Indoors
- Altitude: Up to 2,000 m (6,560 ft) above sea level
- Ambient temperature: 15 °C (59 °F) to 30 °C (86 °F)
- Relative humidity: 80% for temperatures up to 26 °C (79 °F), decreasing linearly to 60% at 30 °C (86 °F)
- Mains supply voltage fluctuations: $\pm 10\%$ of the nominal voltage
- Transient overvoltages: Up to the levels of Overvoltage Category II
- Temporary overvoltages on the mains supply
- Pollution Degree 2

Performance Specifications

The system is designed to meet specifications under these conditions:

- An ambient temperature of 15 °C to 30 °C (59 °F to 86 °F)

Over time, the temperature must remain within a range of 4 °C (7.2 °F), with the rate of the change in temperature not exceeding 2 °C (3.6 °F) per hour. Ambient temperature fluctuations exceeding the limits might result in mass shifts in spectra.

- Relative humidity from 20% to 80%, non-condensing

Equipment Use and Modification



WARNING! Personal Injury Hazard. Contact the SCIEX representative if product installation, adjustment, or relocation is required.



WARNING! Electrical Shock Hazard. Do not remove the covers. Removing the covers might cause injury or malfunctioning of the system. The covers need not be removed for routine maintenance, inspection, or adjustment. Contact a SCIEX Field Service Employee (FSE) for repairs that require the covers to be removed.



WARNING! Personal Injury Hazard. Use SCIEX-recommended parts only. Use of parts not recommended by SCIEX or use of parts for any purpose other than their intended purpose can put the user at risk of harm or negatively impact system performance.



WARNING! Lifting Hazard. Use a mechanical lifting device to lift and move the Echo[®] MS module. If the Echo[®] MS module must be moved manually, then at least four people are required to move it safely. Follow established safe lifting procedures. For the weights of system components, refer to the document: *Site Planning Guide*.



WARNING! Crushing Hazard. Wear protective footwear when moving heavy objects.

If the system is used in an environment or in a manner not prescribed by the manufacturer, then the performance and protection provided by the equipment might be impaired.

Unauthorized modification or operation of the system might cause personal injury and equipment damage, and might void the warranty. Erroneous data might be generated if the system is operated outside the recommended environmental conditions or with unauthorized modifications. Contact an FSE for information on servicing the system.

Principles of Operation

2

This section includes information about the Echo[®] MS core module and the SCIEX OS software. Refer to the document: *System User Guide* for the mass spectrometer for an overview of the mass spectrometer.

The Echo[®] MS core module consists of the Echo[®] MS module, the fluidics module, and the chiller module.

System Overview



WARNING! Lifting Hazard. Use a mechanical lifting device to lift and move the Echo[®] MS module. If the Echo[®] MS module must be moved manually, then at least four people are required to move it safely. Follow established safe lifting procedures. For the weights of system components, refer to the document: *Site Planning Guide*.

The Echo[®] MS system includes the following components:

- An Echo[®] MS module
- A fluidics module
- A chiller module
- A SCIEX Triple Quad 6500+ system with two roughing pumps.
- An OptiFlow Turbo V Ion Source. Refer to the document: *OptiFlow Turbo V Operator Guide*.
- An IonDrive Turbo V Ion Source. Refer to the document: *IonDrive Turbo V Ion Source Operator Guide*
- A SCIEX-supplied computer and monitor with SCIEX OS for instrument optimization, acquisition method development, processing, and data acquisition. For computer specifications and requirements, refer to the *Software Installation Guide* for SCIEX OS.

Hardware Overview

CAUTION: Potential System Damage. Only use the replacement parts specified in the documentation that comes with the system. Use of any other parts might result in instrument damage and malfunction.

The hardware components includes the following components:

- Echo[®] MS module
- Fluidics module
- Chiller module

Figure 2-1 Front and Left Side View: Echo[®] MS Module

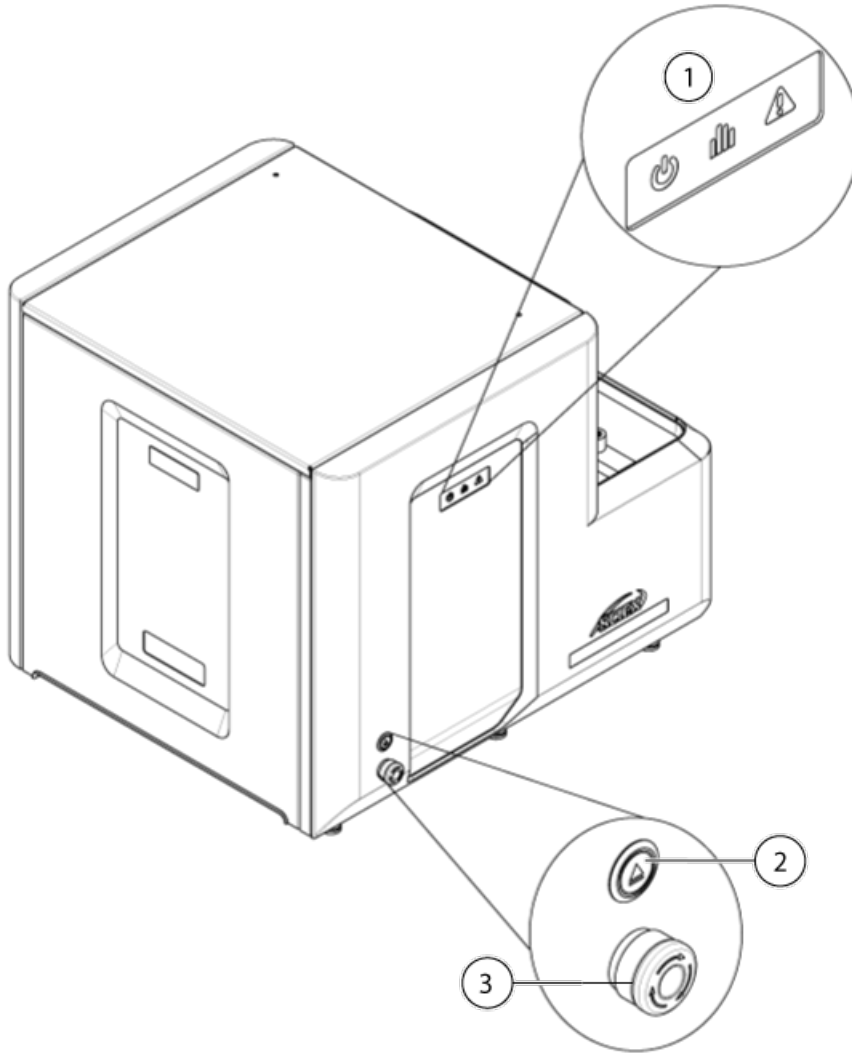

Item	Description
1	Front dress panel status indicator
2	Plate load/unload button
3	Emergency off button

Figure 2-2 Back and Right Side View: Echo[®] MS Module

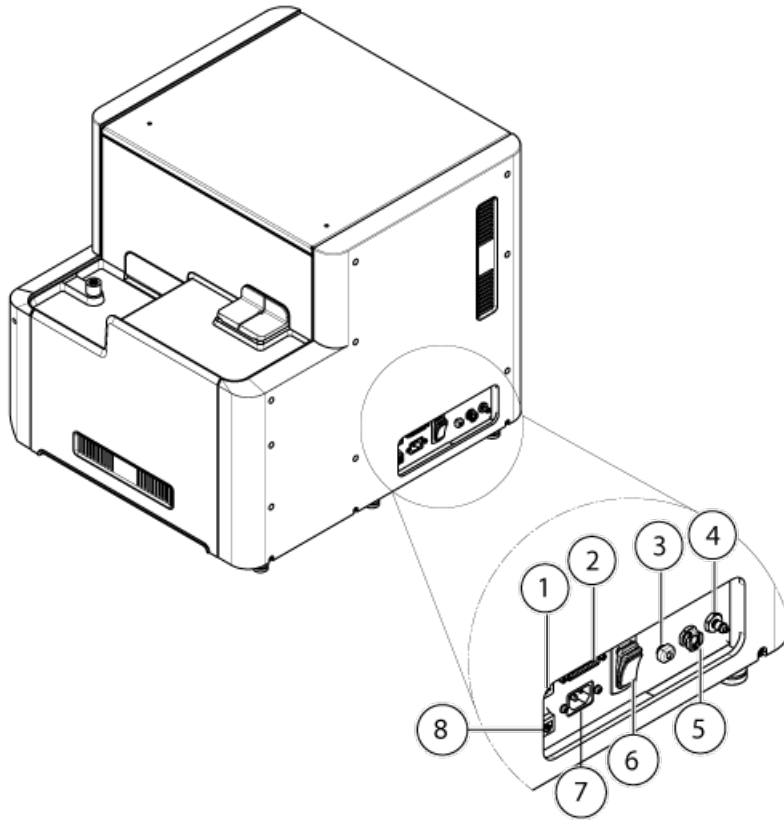

Item	Description
1	Emergency Off (EOFF) connector and EOFF plug
2	Fluid interconnect connector
3	Mobile phase inlet
4	Coupling fluid outlet
5	Coupling fluid inlet
6	Convenience switch
7	Mains power connection
8	Ethernet port

Figure 2-3 Fluidics Module Front and Left Side View

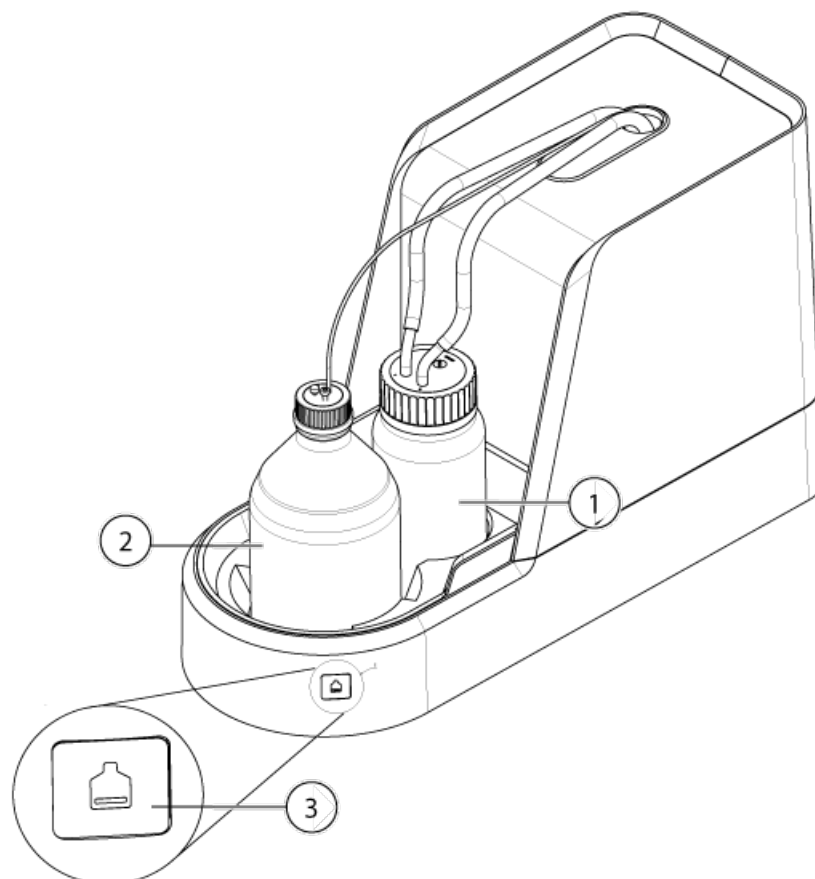

Item	Description
1	Coupling fluid bottle
2	Mobile phase bottle
3	Mobile phase indicator

Figure 2-4 Fluidics Module Back and Right Side View

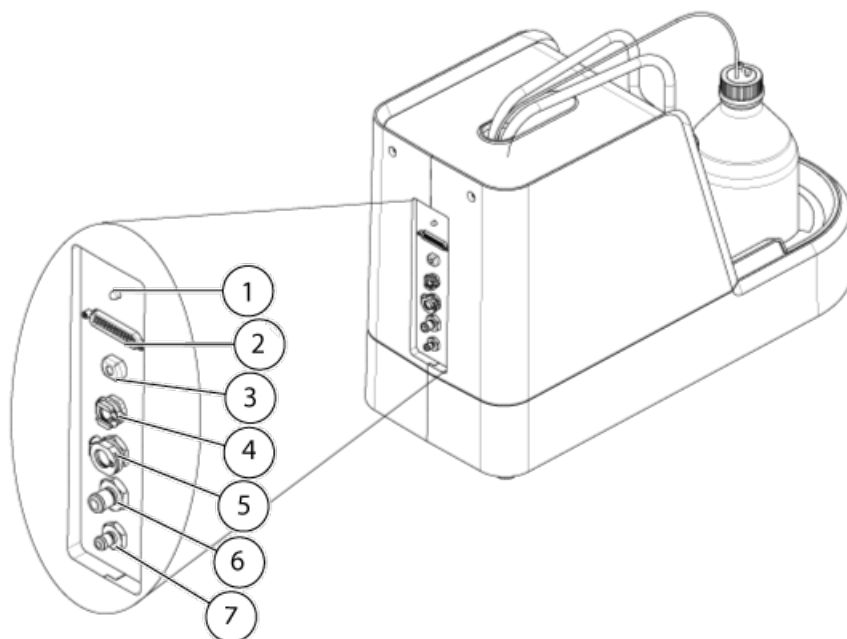

Item	Description
1	Power LED
2	Fluid interconnect connector
3	Mobile phase outlet
4	Coupling fluid inlet
5	Chiller module inlet
6	Chiller module outlet
7	Coupling fluid outlet

Principles of Operation

Figure 2-5 Front View of the Chiller Module



Item	Description
1	Convenience switch

Figure 2-6 Back View of the Chiller Module







Item	Description
1	Circulating fluid inlet
2	Circulating fluid outlet
3	Mains supply connector

Panel Symbols

The following table describes the Echo[®] MS module status LEDs.

Table 2-1 Panel Symbols

LED	Color	Name	Description
	Green	Power	Illuminated when the system is powered up.
	Green	Ready and Scanning	Illuminated when the system is in the Ready state. Flashing when the system is acquiring data.
	Red	Fault	Illuminated when the system encounters a system fault.
	Green	Eject or Retrieve	Flashing when the plate is being ejected or retrieved.

Theory of Operation

The Echo[®] MS module is a high-speed, high-throughput liquid sampling device for sample introduction to a mass spectrometer based on the Acoustic Droplet Ejection (ADE) and Open-Port Interface (OPI) technology. The Echo[®] MS module performs the automated, manual handling of, or contactless introduction of the samples to the mass spectrometer. The Echo[®] MS module interfaces with SCIEX OS. Sample management, data acquisition, and data processing are monitored and analysed from the acquisition computer.

The sample plate is put on the plate gripper either manually, or by a robotic handler. The user then optimizes and sets the parameters for a method in SCIEX OS. The plate gripper inserts the sample well-plate in the Echo[®] MS module. The Echo[®] MS module introduces the sample from the well plate to the mass spectrometer using the ADE and OPI technology.

Operating Instructions—Device Configuration

3

Use the Configuration workspace to:

- Activate and deactivate devices
- Add and delete devices
- Edit device settings
- Test the devices

Add an Echo[®] MS Core Module Device

Note: To avoid any activation issues, always add the mass spectrometer Module before adding any other devices.

1. Open the Configuration workspace.
2. Click **Devices**.
3. If the devices are active, then click **Deactivate**.
4. Click **Add**.
The Device dialog opens.
5. In the **Type** list, select the **Integrated System**.
6. In the **Model** list, select **Echo[®] MS**.
7. Click **Settings** to edit settings or restore default values.
8. Click **Test Device** to verify that the device is configured correctly and available for use.
9. Click **Save**.
10. Repeat step 4 to step 9 as required.
11. Select the **Activate** check box beside each device to be activated, and then click **Activate Devices**.
12. To edit or delete devices, refer to the *Help system*.

Deactivate Devices

1. Open the Configuration workspace.
2. Click **Devices**.
3. Click **Deactivate**.

Fluid Line Connections

Prerequisites

- Make sure that the site requirements are met. Refer to the document: *Site Planning Guide*. This document includes information about the mains supply and connections, ventilation, and site clearance requirements. Contact SCIEX for a copy of the *Site Planning Guide*, if required. For contact information, go to sciex.com/contact-us.
- The Echo[®] MS Module convenience switch is turned off.
- The chiller module power switch is turned off.

1. Connect the two fluidics-module-to-coupling fluid tubes from the Echo[®] MS module to the fluidics module.

Figure 4-1 Fluid Line Connection

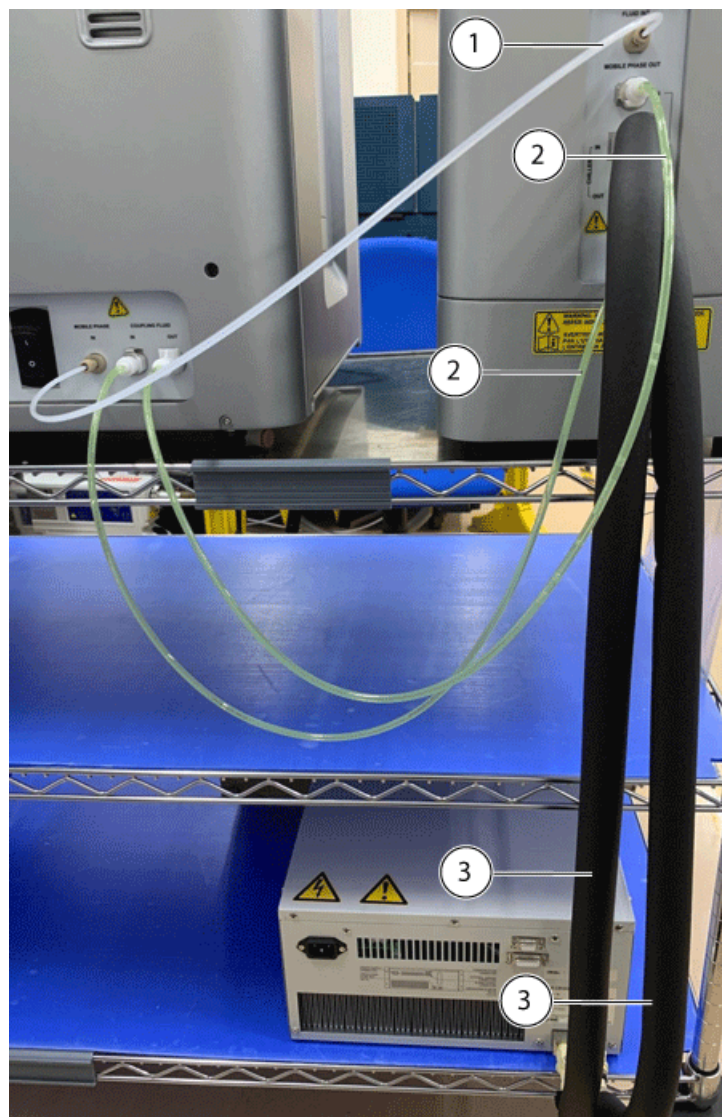

Item	Description
1	Mobile phase external tube
2	Fluidics module-to-coupling fluid tube
3	Fluidics module to chiller module tube

2. Connect the mobile phase external tube from the Echo[®] MS module to the fluidics module.

System Preparation

3. Connect the two fluidics module-to-chiller module tubes from the Echo[®] MS module to the chiller module.

Prerequisites

Prerequisites

- Start up the SCIEX Triple Quad 6500+ system. Refer to the *System User Guide* for the mass spectrometer.
- Install the ion source. Refer to the document: *OptiFlow Turbo V Ion Source Operator Guide*.

Start Up the Echo[®] MS Module



WARNING! Electrical Shock Hazard. Make sure that the system can be disconnected from the mains supply outlet in an emergency. Do not block the mains supply outlet.

Note: Before operating the instrument, read the safety information in the section: [Operational Precautions and Limitations](#).

Prerequisites

- Make sure that the site requirements are met. Refer to the document: *Site Planning Guide*. This document includes information on the mains supply and connections, exhaust, and site clearance requirements. Contact SCIEX for a copy of the *Site Planning Guide*, if required. For contact information, go to sciex.com/contact-us.
- The Echo[®] MS module convenience switch is turned off and the mains supply cable is plugged in the Echo[®] MS module
- The chiller module power switch is turned off and the mains supply cable is connected to the chiller module
- The connections are connected on the Echo[®] MS module, fluidics module, and the chiller module.
- The Ethernet cable is connected to both the Echo[®] MS module and the computer.
- Replace the coupling fluid. Refer to the section: [Replace the Coupling Fluid](#).
- The EOFF plug is connected to the EOff connector.

1. Turn on the Echo[®] MS module convenience switch.
The convenience switch is at the back of the Echo[®] MS module.

Figure 4-2 Echo[®] MS Module Convenience Switch



Item	Description
1	Convenience switch

2. Turn on the chiller module convenience switch.

Figure 4-3 Chiller Module Convenience Switch



Item	Description
1	Convenience switch

3. Turn on the computer.
4. Open SCIEX OS.

Purge the Flow Lines

Prerequisites

- [Add the Mobile Phase Solvent](#)
- [Replace the Coupling Fluid](#)

1. Open SCIEX OS.
2. Click **Direct device control** ()
The Device Control dialog opens.
3. Click **Tools > Maintenance**.
The Echo[®] MS - Maintenance window opens.

4. In the Purge Solvent Line group, under **Solvent Pump**, click **Purge**.
In the Solvent Pump group, the **Running** status is shown. The default purge time is 60 seconds.
5. After the purge is completed, close the Echo[®] MS - Maintenance window.

Table 5-1 Manual Workflow

Task	Refer To
Configure the mass spectrometer in the Configuration workspace in SCIEX OS. 1. Configure the mass spectrometer in low mass mode. 2. Configure the IonDrive Turbo V ion source. 3. Configure the integrated syringe pump.	Refer to the following: <ul style="list-style-type: none"> • <i>System User Guide</i> for the mass spectrometer • Operating Instructions—Device Configuration
In the MS Tune workspace, tune the mass spectrometer using the IonDrive Turbo V ion source and the syringe pump.	"MS Tune Workspace", in the <i>Software User Guide</i> or <i>Help System</i> .
Configure the mass spectrometer in the Configuration workspace in SCIEX OS. 1. Configure the mass spectrometer in low mass mode. 2. Configure the OptiFlow Turbo V ion source.	<ul style="list-style-type: none"> • <i>System User Guide</i> for the mass spectrometer • Operating Instructions—Device Configuration
Configure the Echo [®] MS System in the Configuration workspace in SCIEX OS.	Operating Instructions—Device Configuration .

Table 5-1 Manual Workflow (continued)

Task	Refer To
In SCIEX OS, create an the MS method using the Guided MRM feature and then create an AE method.	<ul style="list-style-type: none"> • "Create an AE Method", in the <i>Software User Guide</i> or <i>Help System</i> • "MS Method Workspace", in the <i>Software User Guide</i> or <i>Help System</i> • "Analytics Workspace", in the <i>Software User Guide</i> or <i>Help System</i>
Create a processing method in the Analytics workspace in SCIEX OS.	<ul style="list-style-type: none"> • "Analytics Workspace", in the <i>Software User Guide</i> or <i>Help System</i>
Set up and submit a batch for data acquisition and processing using SCIEX OS remotely.	<ul style="list-style-type: none"> • Third-party software provider. Work with the third-party service provider to create an automatic workflow.

Table 5-2 Automatic Workflow

Task	Software Access
Configure the mass spectrometer in the Configuration workspace in SCIEX OS. <ol style="list-style-type: none"> 1. Configure the mass spectrometer in low mass mode. 2. Configure the IonDrive Turbo V ion source. 3. Configure the integrated syringe pump. 	Refer to the section: <i>System User Guide</i> for the mass spectrometer and refer to the section: Operating Instructions—Device Configuration .
In the MS Tune workspace, tune the mass spectrometer using the IonDrive Turbo V ion source, and the syringe pump.	Refer to the section: "MS Tune Workspace", in the <i>Software User Guide</i> or <i>Help System</i> .

Method Developer Workflow

Table 5-2 Automatic Workflow (continued)

Task	Software Access
Configure the mass spectrometer in the Devices workspace in SCIEX OS. <ol style="list-style-type: none"> Configure the mass spectrometer in low mass mode. Configure the OptiFlow Turbo V ion source. 	Refer to the section: <i>System User Guide</i> for the mass spectrometer and refer to the section: Operating Instructions—Device Configuration .
Configure the Echo [®] MS System in the Configuration workspace in SCIEX OS.	Refer to the section: Operating Instructions—Device Configuration .
In SCIEX OS, optimize the MS method using the Guided MRM feature and then create an AE method.	<ul style="list-style-type: none"> Refer to the section: "Create an AE Method", in the <i>Software User Guide</i> or <i>Help System</i> Refer to the section: "MS Method Workspace", in the <i>Software User Guide</i> or <i>Help System</i> Refer to the section: "Analytics Workspace", in the <i>Software User Guide</i> or <i>Help System</i>
(Optional) Create a processing method in the Analytics workspace in SCIEX OS.	<ul style="list-style-type: none"> Refer to the section: "Create an AE Method", in the <i>Software User Guide</i> or <i>Help System</i> Refer to the section: "MS Method Workspace", in the <i>Software User Guide</i> or <i>Help System</i> Refer to the section: "Analytics Workspace", in the <i>Software User Guide</i> or <i>Help System</i>
In the scheduler user interface, submit a batch using the optimized MRM, AE, and processing methods.	<ul style="list-style-type: none"> Refer to the section: "Batch Workspace", in the <i>Software User Guide</i> or <i>Help System</i> Refer to the section: "MS Method Workspace", in the <i>Software User Guide</i> or <i>Help System</i> Refer to the section: "Analytics Workspace", in the <i>Software User Guide</i> or <i>Help System</i>

Prerequisites

- Make sure that the Echo[®] MS probe is installed. Refer to the document: *OPI Electrode Assembly Replacement Quick Start Guide*.

Prepare the Plates

1. Put the sample plates in the centrifuge.
2. Configure the centrifuge with the following recommended settings:
 - For AQ fluids: 1,533 g for 5 minutes
 - For SP fluids: 170 g for 2 minutes

Note: A 6 inch long-arm centrifuge is recommended for a best performance.

Note: The sample plates must be centrifuged to remove any bubbles created when samples are dispensed to the plate.

Note: The Centrifuge speed (rpm) is calculated in inches as follows:
 $RPM = \sqrt{G\text{-Force} / (0.0000284 \times \text{Rotor Radius})}$

3. Remove the sample plate and then put it on the orbital well-plate shaker.
4. Shake the plates with the following recommended shaker settings:
 - For AQ fluids: 1,350 rpm for 5 minutes
 - For SP fluids: 1,350 rpm for 1 minute
5. Put the sample plate on the Echo[®] MS core module.

Note: We recommend that the sample plate be prepared with the preceding specified settings. The centrifuge and shaker settings must be confirmed effective by the user for the centrifuge, shaker and fluid combination used.

Load the Plate Manually

CAUTION: Potential System Damage. Do not touch the plate gripper when it is moving. Touching the plate gripper might result in damage to the plate gripper. The Plate load/unload LED flashes when the gripper assembly is moving.



WARNING! Pinching Hazard. Be careful not to pinch fingers when the plate gripper is moving.

Note: Before operating the instrument, read the safety information in the section: [Operational Precautions and Limitations](#).

Use one of the following procedures to load the plate.

Load the Plate Using Software

1. Open the Echo[®] MS status window.
2. Click **Out**.
The gripper assembly extends with the sample plate.
3. Put the sample plate in the plate gripper assembly.
4. Click **In**.
The gripper assembly retracts with the sample plate.
5. Close the Echo[®] MS status window.

Load the Plate Using Hardware

1. Press the **Plate load/unload** button on the left side of the Echo[®] MS module.
The gripper assembly extends.
2. Put the sample plate in the gripper assembly.
3. Press the **Plate load/unload** button on the left side of the Echo[®] MS module.
The gripper assembly with the sample plate retracts.

Note: The Plate load/unload LED flashes when the gripper assembly extends and retracts.

Submit the Batch and then Start the Acquisition

Note: Before operating the instrument, read the safety information in the section: [Operational Precautions and Limitations](#).

Submit a batch and then start the acquisition in the Queue workspace. Refer to the section: "Batch Workspace," in the *Software User Guide* or *Help System* .

Emergency Off Function

The emergency off function stops all mechanical motion and turns off the fluid flow activity in the Echo[®] MS module and the fluidics module.

The emergency off function consists of the following:

- The emergency off button on the front panel of the Echo[®] MS module.
- The emergency off connector and plug on the back panel of the Echo[®] MS module.

Enable the emergency off function, in one of these ways:

- Press the emergency off button in the front panel.
- Remove the jumper connector on the emergency off connector and plug on the back panel.

The emergency off connector and plug on the back panel allows the user to connect a closed external button or relay. Shorting between both of the pins disables the emergency off function. The emergency off connector and plug accept a 26AWG to 16AWG cable. The resistance of the cable, including the closed external button or the relay, must not exceed 500 ohms.

Note: Make sure to use the shielded cable or the unshielded cable with a ferrite core added.

Figure 6-1 Shielded Cable or Unshielded Cable With Ferrite Core



Figure 6-2 Emergency Off Button on the Front Panel of the Echo[®] MS Module



Item	Description
1	Emergency off button

Figure 6-3 Emergency Off Connector and Plug on the Back Panel of the Echo[®] MS Module



Item	Description
1	Emergency off connector and plug

Use the emergency off button if the following is observed in the Echo[®] MS module:

- Pinch hazard
- A loud or potentially damaging noise
- Liquid leakage

When the emergency off button is pressed, the following events occur:

- The Echo[®] MS module motion activity stops.
- The fluid flow is turned off.
- Acquisition stops and an error message is shown in SCIEX OS.
- The fault LED is illuminated.

Operating Instructions

- A fault indicator is shown in the Device Control dialog. The **Error** field shows that the emergency off button was activated.

Figure 6-4 Device Control Dialog

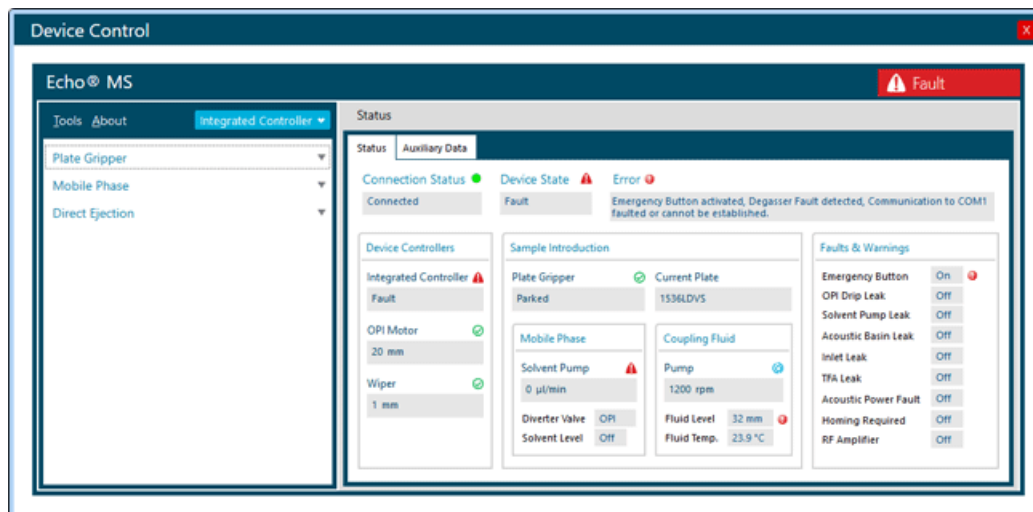

Activating the emergency off button does not turn off the following:

- The Echo[®] MS module controller and power supply

Note: However, the power output is interrupted.

- External communications, such as Ethernet and USB
- The chiller module

Use the Emergency Off Button

Note: Make sure that all of the operational precautionary measures highlighted in the documentation are followed.



WARNING! Electrical Shock Hazard. Make sure that the system can be disconnected from the mains supply outlet in an emergency. Do not block the mains supply outlet.

- Press the emergency off button on the front panel of the Echo[®] MS module.

Reset the Emergency Off Button

Note: The emergency off button can be reset either from the front panel or the back panel.

If the emergency off button is used to stop the Echo[®] MS module, then start the system by doing the following:

1. Resolve the following issues:
 - Pinch hazard
 - A loud or potentially damaging noise
 - Water leakage
2. Reset the Echo[®] MS module by turning the emergency off button in the direction of the arrows on the button until it comes out.

Figure 6-5 Turn the Emergency Off Button Clockwise



The emergency off button returns to its operating position and the supply of power to the Echo[®] MS module is turned on.

If the emergency off button is pressed, then the Fault state is shown in the Device Control dialog.

Figure 6-6 Fault Status

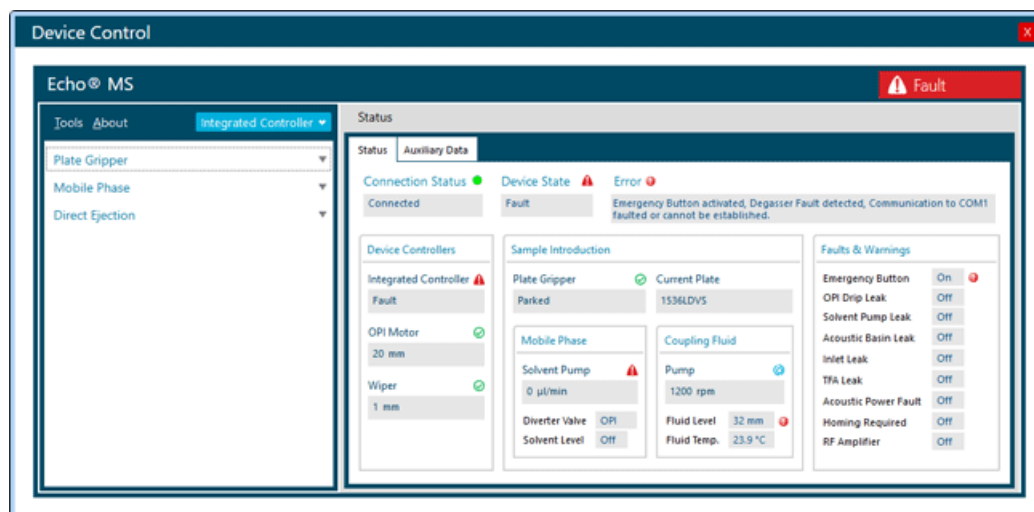

After the emergency off button is reset, the system clears the error message and the Idle state is shown in the Device Control dialog.

Flush the Electrode Assembly After Acquisition

1. Open SCIEX OS.
2. Open the Configuration workspace.
3. Click **Queue**.

Verify that the idle time of the mass spectrometer is set to a minimum of 30 minutes.

Note: When the system is on a Standby mode, the mobile phase continues to be delivered to the to the OptiFlow Turbo V ion source through the Open-Port Interface (OPI), thus flushing the electrode assembly. After the defined time is completed, the mobile phase pump stops with the detection of overflow at the OPI.

Turn off the Echo[®] MS System

Prerequisite Procedures

- Deactivate the devices. Refer to the section: [Deactivate Devices](#).

1. Turn off the Echo MS module convenience switch. Refer to the figure: [Figure 4-2](#).
2. Turn off the chiller module convenience switch. Refer to the figure: [Figure 2-5](#).

Resume the Echo[®] MS System after a Power Shutdown

Prerequisites

- Refer to the section: [Replace the Coupling Fluid](#)

1. Turn on the Echo[®] MS module convenience switch. Refer to the figure: [Figure 4-2](#).

Routine Maintenance

2. Turn on the chiller module convenience switch. Refer to the figure: [Figure 2-5](#).
3. Open SCIEX OS.

Waste Disposal

Properly dispose of any effluent waste in an appropriate chemical waste container. After disposing of the waste liquid, make sure that the waste tubing has no loops and that the end of the tubing protrudes from the waste bottle cap, where about 1 inch (2.5 cm) of the tubing is shown.



WARNING! Biohazard or Toxic Chemical Hazard. Follow local directives when disposing of chemicals and the remains of the prepared samples, if applicable. They might contain regulated compounds and biohazardous agents.

Clean the Surfaces

Clean the external surfaces of the system after a spill or when they become dirty.

Required Materials
<ul style="list-style-type: none">• Soft cloth

1. Use a soft, damp cloth to clean the surfaces of the system.
2. Use a soft, dry cloth to remove any moisture from the surfaces.

Add the Mobile Phase Solvent



WARNING! Toxic Chemical Hazard. Take care when filling mobile phase bottles. Refer to the chemical product Safety Data Sheets and take appropriate safety precautions. Do not fill the mobile phase bottle while it is in the side tray. Disconnect the fluid line from the bottle, fill the bottle in a safe location, and then install the bottle and fluid line in the side tray.

1. Open SCIEX OS.
2. Click **Direct device control** ()
The Echo[®] MS Device Control dialog opens.
3. Click **Mobile Phase**.

4. In the Solvent Pump group, click **Stop** to turn off the solvent pump.
5. Remove the cap, with the mobile phase tubing and the suction filter attached, from the mobile phase bottle.
6. Remove the mobile phase bottle from the fluidics module.
7. Add 2 mL of formic acid and 1998 mL of methanol, making a total quantity of 2 L, to the mobile phase bottle in a safe location, taking the appropriate safety precautions.
8. Install the mobile phase bottle in the fluidics module.
9. Put the mobile phase solvent cap, with the mobile phase tubing and the suction filter attached, on the mobile phase bottle. Tighten the cap.

Note: Make sure that the mobile phase tubing and the attached suction filter are is submerged in the mobile phase solvent.

10. Click **Direct device control** ()
The Device Control dialog opens.
11. Click **Tools > Maintenance**.
12. To fill the mobile phase line, click **Prime**.

Tip! Use the **Purge** function to flush the line.

Figure 7-1 Maintenance

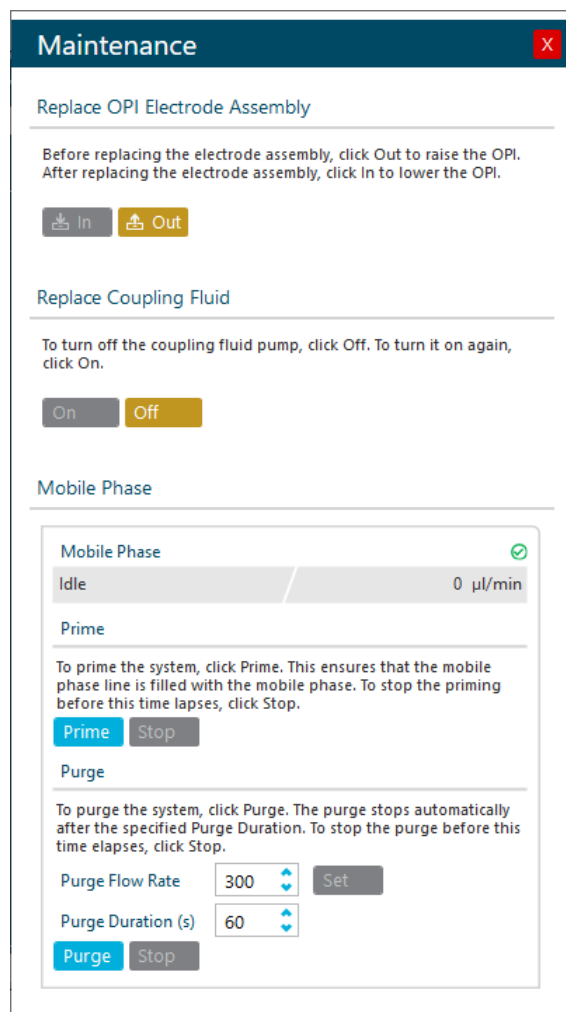

Replace the Coupling Fluid

1. Open SCIEX OS.
2. Click **Direct device control** ()
The Device Control dialog opens.
3. Click **Tools > Maintenance**.
The Echo[®] MS - Maintenance dialog opens.

4. Turn off the coupling fluid pump by clicking **Off** in the Replace Coupling Fluid group.
5. Remove the coupling fluid bottle cap with the coupling fluid tubing and the water-level sensor attached.
6. Remove the coupling fluid bottle from the fluidics module.
7. Discard any water in the coupling fluid bottle.
8. Add 900 mL of deionized water to the coupling fluid bottle.

Note: Add 1 L of deionized water to the coupling fluid bottle after the Echo[®] MS System is installed for the first time.

9. Install the coupling fluid bottle in the fluidics module.
10. Put the coupling fluid bottle cap, with the coupling fluid tubing and the water-level sensor attached, on the coupling fluid bottle. Then tighten the cap.

Note: Make sure that the coupling fluid is replaced every week.









Inspect the Fluidics Module

1. Inspect the fluidics module for evidence of biological growth or debris.
If either is present, then contact an FSE to clean the fluidics module.
2. Visually inspect the system tubing and fittings.
Look for broken fittings and dried deposits that might indicate a slow leak.
 - a. Tighten any loose connections.
 - b. If a fluid tubing connection is broken, replace the tubing and then clean the fluidics module. Contact an FSE to replace and then clean the fluidics module.
3. Visually inspect for pinched tubing and the bubbles formed in the flow path.
Straighten the tubing. If this does not resolve the issue, then replace the tubing.











Glossary of Symbols









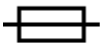

A

Note: Not all of the symbols in the following table are applicable to every instrument.





Symbol	Description
	Australian Regulatory Compliance Mark. Indicates that the product complies with Australian Communications Media Authority (ACMA) EMC Requirements.
	Alternating current
A	Amperes (current)
	Asphyxiation Hazard
	Authorized representative in the European community
	Biohazard
	CE Marking of Conformity
	cCSAus mark. Indicates electrical safety certification for Canada and USA.
	Catalog number
	Caution. Consult the instructions for information about a possible hazard. Note: In SCIEX documentation, this symbol identifies a personal injury hazard.







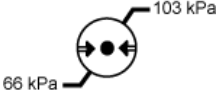
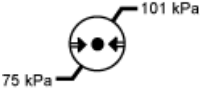
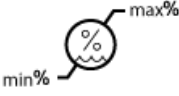

Glossary of Symbols

Symbol	Description
	China RoHS Caution Label. The electronic information product contains certain toxic or hazardous substances. The center number is the Environmentally Friendly Use Period (EFUP) date, and indicates the number of calendar years the product can be in operation. Upon the expiration of the EFUP, the product must be immediately recycled. The circling arrows indicate the product is recyclable. The date code on the label or product indicates the date of manufacture.
	China RoHS logo. The device does not contain toxic and hazardous substances or elements above the maximum concentration values and it is an environmentally-friendly product that can be recycled and reused.
	Consult instructions for use.
	Crushing Hazard
	cTUVus mark for TUV Rheinland of North America
	Data Matrix symbol that can be scanned by a barcode reader to obtain a unique device identifier (UDI)
	Environmental Hazard
	Ethernet connection
	Explosion Hazard
	Eye Injury Hazard

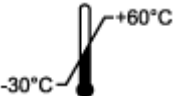
Symbol	Description
	Fire Hazard
	Flammable Chemical Hazard
	Fragile
	Fuse
Hz	Hertz
	International safety symbol "Caution, risk of electric shock" (ISO 3864), also known as High Voltage symbol If the main cover must be removed, then contact a SCIEX representative to prevent electric shock.
	Hot Surface Hazard
	In Vitro Diagnostic Device
	Ionizing Radiation Hazard
	Keep dry. Do not expose to rain. Relative humidity must not exceed 99%.
	Keep upright.
	Lacerate/Sever Hazard

Glossary of Symbols

Symbol	Description
	Laser Radiation Hazard
	Lifting Hazard
	Magnetic Hazard
	Manufacturer
	Moving Parts Hazard
	Pacemaker Hazard. No access to people with pacemakers.
	Pinching Hazard
	Pressurized Gas Hazard
	Protective Earth (ground)
	Puncture Hazard
	Reactive Chemical Hazard
	Serial number

Symbol	Description
	Toxic Chemical Hazard
	Transport and store the system within 66 kPa to 103 kPa.
	Transport and store the system within 75 kPa to 101 kPa.
	Transport and store the system within the specified minimum (min) and maximum (max) levels of relative humidity, noncondensing.
	Transport and store the system within $-30\text{ }^{\circ}\text{C}$ to $+45\text{ }^{\circ}\text{C}$.
	Transport and store the system within $-30\text{ }^{\circ}\text{C}$ to $+60\text{ }^{\circ}\text{C}$.
	USB 2.0 connection
	USB 3.0 connection
	Ultraviolet Radiation Hazard
	United Kingdom Conformity Assessment Mark
VA	Volt Ampere (power)
V	Volts (voltage)
	WEEE. Do not dispose of equipment as unsorted municipal waste. Environmental Hazard

Glossary of Symbols

Symbol	Description
W	Watts
	<i>yyyy-mm-dd</i> Date of manufacture

Glossary of Warnings

B

Note: If any of the labels used to identify a component become detached, contact a Field Service Employee (FSE).

Label	Translation (if applicable)
FOR RESEARCH USE ONLY. NOT FOR USE IN DIAGNOSTIC PROCEDURES.	FOR RESEARCH USE ONLY. NOT FOR USE IN DIAGNOSTIC PROCEDURES.

Contact Us

Customer Training

- In North America: NA.CustomerTraining@sciex.com
- In Europe: Europe.CustomerTraining@sciex.com
- Outside the EU and North America, visit sciex.com/education for contact information.

Online Learning Center

- [SCIEX Now Learning Hub](#)

SCIEX Support

SCIEX and its representatives maintain a staff of fully-trained service and technical specialists located throughout the world. They can answer questions about the system or any technical issues that might arise. For more information, visit the SCIEX website at sciex.com or contact us in one of the following ways:

- sciex.com/contact-us
- sciex.com/request-support

CyberSecurity

For the latest guidance on cybersecurity for SCIEX products, visit sciex.com/productsecurity.

Documentation

This version of the document supercedes all previous versions of this document.

To view this document electronically, Adobe Acrobat Reader is required. To download the latest version, go to <https://get.adobe.com/reader>.

To find software product documentation, refer to the release notes or software installation guide that comes with the software.

To find hardware product documentation, refer to the *Customer Reference* DVD that comes with the system or component.

The latest versions of the documentation are available on the SCIEX website, at sciex.com/customer-documents.

Note: To request a free, printed version of this document, contact sciex.com/contact-us.
